

## Standard Product Features

- 🔌 **Supply Voltage 12-24V**
- 🔌 **Brighter LED's**
- 🔌 **Relegendable Buttons**
- 🔌 **Multicolor indicator rings**
- 🔌 **Sealed IP68**
- 🔌 **Vertical or horizontal mount**
- 🔌 **CRM, Designer, ECS firmware options**
- 🔌 **Improved thermal dissipation**
- 🔌 **Full color LED indicators including pure white**
- 🔌 **Standard and custom legends (no mins, no set up fees)**
- 🔌 **All LEDs active power consumption only 70 mA @ 12V**
- 🔌 **Simplified CAN messaging using CANconnect software**



## Improved Product Features

with Designer Firmware

- 🔌 **256 step brightness control for each color**
- 🔌 **New LED visual effects (blink, pulse, spin, ripple, split)**
- 🔌 **On/Off, momentary, toggle, scroll/step functions programmable for each key**
- 🔌 **Autonomous operation (key press causes LED to change state without feedback from external device)**
- 🔌 **NMEA200 bus compliant (support ISO requests, address claim, binary status 127501 and binary control)**

## Protocols & Accessories

- 🔌 **CAN Open**
- 🔌 **J1939**
- 🔌 **NMEA2000**
- 🔌 **Free Software Utility**
- 🔌 **Accessories Catalog**
- 🔌 **Connector Options include Deutsch, Molex and more**

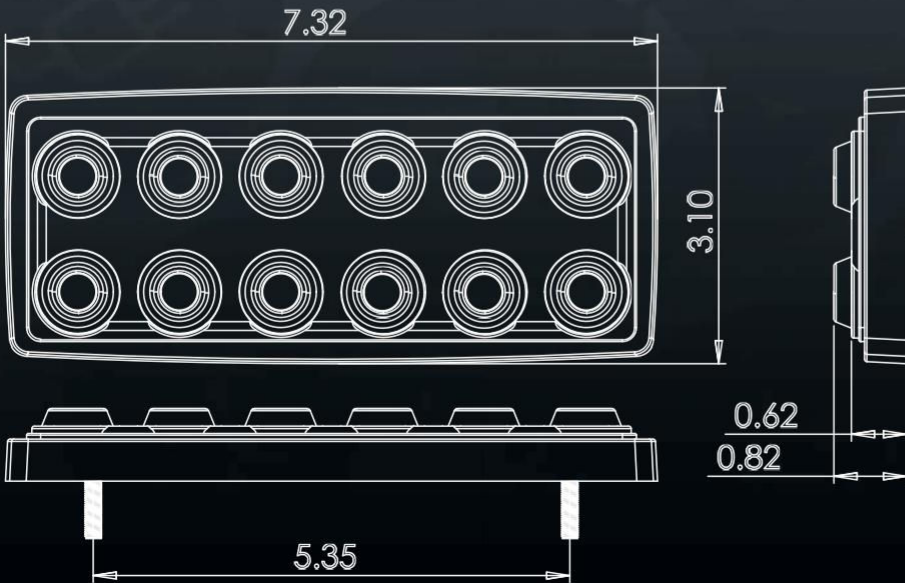
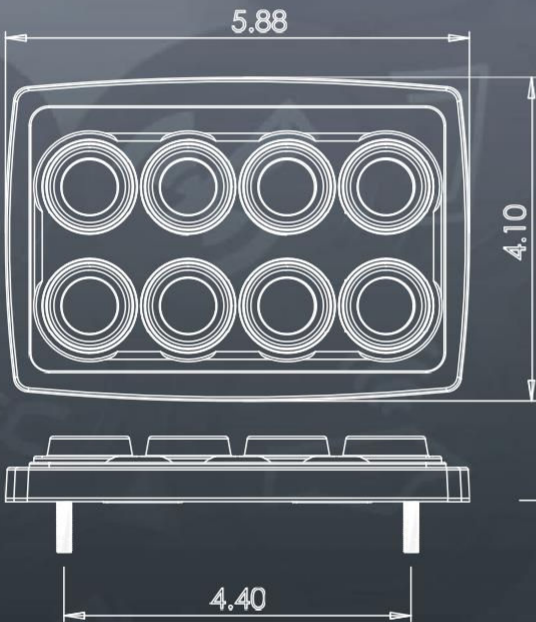
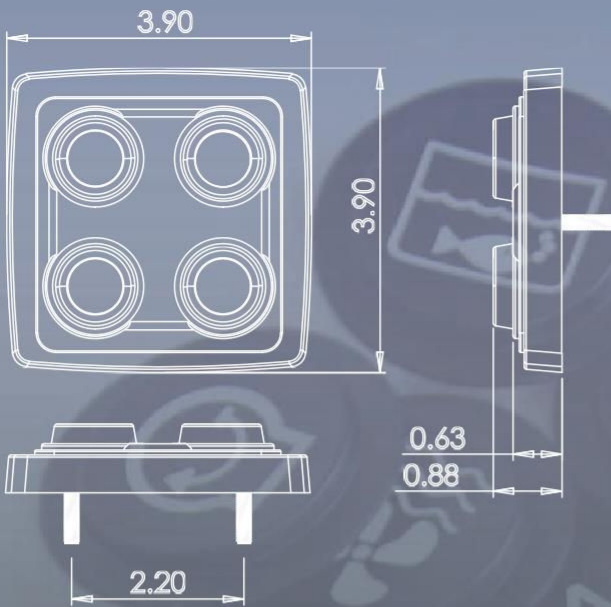

PKU Inserts are available  
in 2 different sizes 12 & 19mm

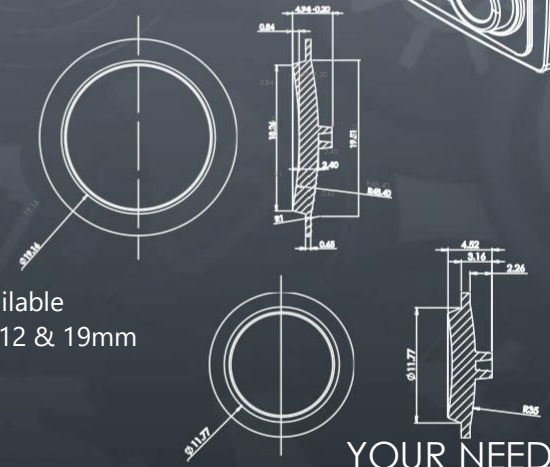
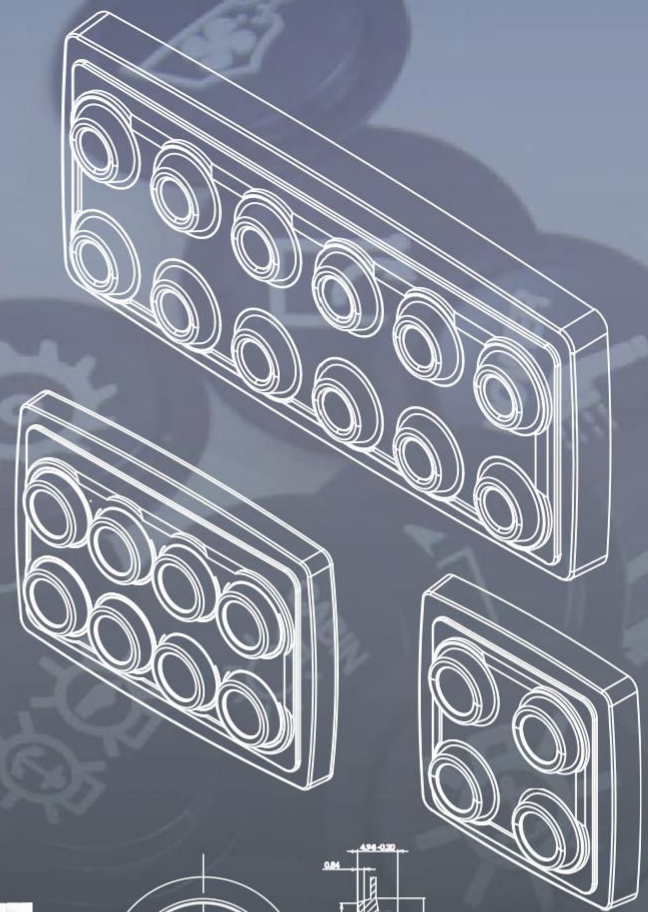

YOUR NEEDS  
ARE DYNAMIC  
CHOOSE A  
PRODUCT THAT  
ADAPTS TO YOU.